

LUXOR-32P series

320W switching power supply



Features

- AC input voltage range selected by switch.
- Small volume, low weight, high efficiency.
- Protections: short circuit/over load/over voltage/over temperature.
- DC fan forced air cooling.
- Built-in fan speed control.
- LED indicator for power on.
- 100% full load burn-in test.
- 3 years warranty.

Specification



	Model	LUXOR-25P5	LUXOR-32P12	LUXOR-32P15	LUXOR-32P24	LUXOR-32P48
Output	DC Voltage	5V	12V	15V	24V	48V
	Voltage tolerance	±1%	±1%	±1%	±1%	±1%
	Rated current	50A	29A	23A	14.6A	7.3A
	Current range	0 ~ 50A	0 ~ 29A	0 ~ 23A	0 ~ 14.6A	0 ~ 7.3A
	Rated power	250W	348W	345W	350.4W	350.4W
	Ripple&noise	150mVp-p	150mVp-p	150mVp-p	200mVp-p	200mVp-p
	DC voltage ADJ. range	±10%	±10%	±10%	±10%	±10%
	Setup, rise, hold up time	1000ms, 100ms, 30ms/230VAC				
Input	Voltage range	90 ~ 132VAC/180 ~ 264VAC (selected by switch) 47 ~ 63Hz, 255 ~ 373VDC				
	AC current	6.5A/115V 4A/230VAC				
	Efficiency	80%	82%	82%	82%	84%
	Inrush current	Cold start 25A/115V 50A/230VAC				
	Leakage current	<3.5mA/240VAC				
Protection	Overload	Rated output power 110% ~ 135% Start overload protection				
		Protection type: hiccup mode, auto-recovery after fault condition is removed				
	Over voltage	Rated output power 115% ~ 135% Start overload protection				
Over temperature	≥85°C±5°C (TSW1 detect on heat sink of power transistor)					
	Protection mode: cutoff output, auto-recovery after temperature become normal					
Environment	Working temp, humidity	-10°C ~ +60°C; 20% ~ 90% RH (Please refer to "derating curve")				
	Storage temp, humidity	-20°C ~ +85°C; 10% ~ 95% RH Non-condensing				
	Withstand vibration	10 ~ 500Hz, 2G 10 min/1 Cycle, Period for 60min, Each axes				
Safety	Withstand voltage	I/P-O/P: 1.5KVAC I/P-FG: 1.5KVAC O/P-FG: 0.5KVAC				
	Isolation resistance	I/P-O/P: I/P-FG, O/P-FG: 100M Ohms/500VDC				
Fit standard	Safety standard	EN61347-1; EN61347-2-13				
	EMC standard	EN55015; EN61547				
Others	Weight	0.80kg				
	Dimension	199*99*48mm (L*W*H)				
	Packing	0.80kg/24pcs/20kg/1.20CUFT				

Note:

1. All parameters NOT specially mentioned are measured at 230VAC input, rated load and 25°C of ambient temperature.
2. Ripple & noise are measured at 20MHz of bandwidth by using a 12" twisted pair-wire terminated with a 0.1uf & 47uf parallel capacitor.
3. Tolerance: includes set up tolerance, line regulation and load regulation.

Mechanical specification

Unit mm

Terminal Pin No. Assignment

Pin No	Assignment
8	AC/L
9	AC/N
7	FG \perp
4~6	DC OUTPUT -V
1~3	DC OUTPUT +V

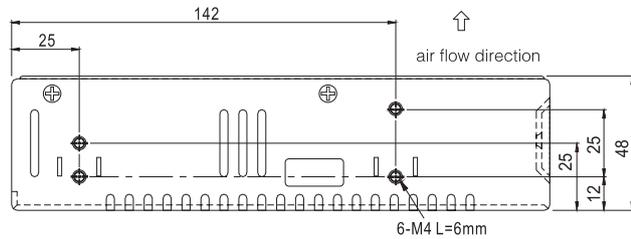
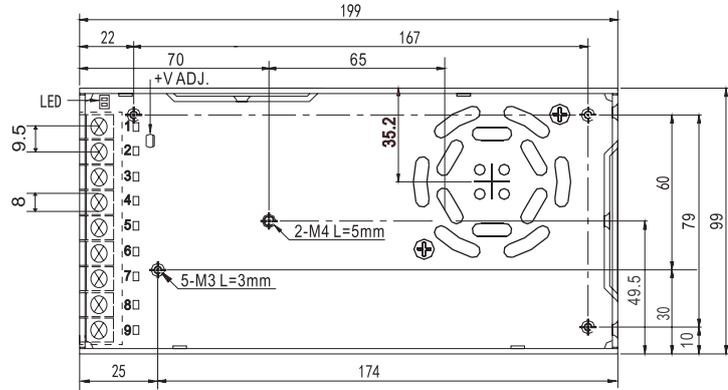

Block diagram

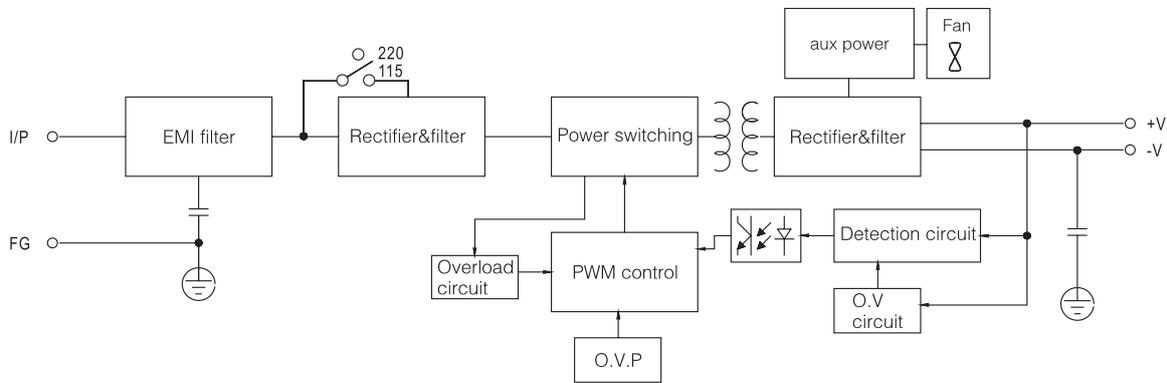

Derating curve

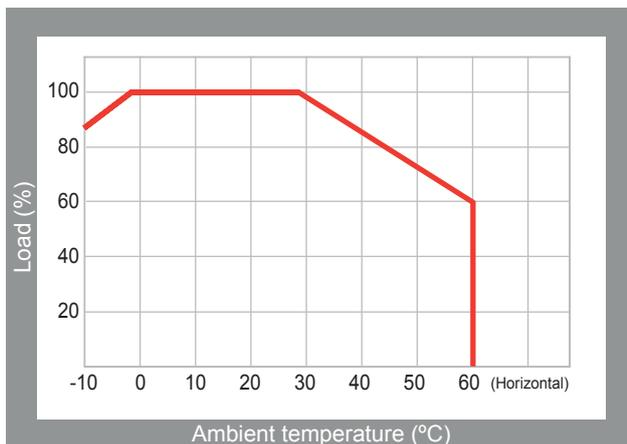

Static characteristics

